

# Design and Development of a Power-Free Smart Cooler Box Using Phase Change Materials (PCMs) for Last-Mile Cold Chain Logistics

Helvina Aulia Zahra<sup>1</sup>, Ahmad Rusdiansyah<sup>1\*</sup>, Ratna Sari Dewi<sup>1</sup>, Rindi Kusumawardani<sup>1</sup>,  
Azzah Dyah Pramata<sup>2</sup>, Fadila Isnaini<sup>3</sup>

<sup>1</sup>) Faculty of Industrial Technology and Systems Engineering, Department of Industrial and Systems Engineering, Institut Teknologi Sepuluh Nopember

<sup>2</sup>) Faculty of Industrial Technology and Systems Engineering, Department of Materials and Metallurgical Engineering, Institut Teknologi Sepuluh Nopember

<sup>3</sup>) Faculty of Creative Design and Digital Business, Department of Business Management, Institut Teknologi Sepuluh Nopember

Kampus ITS Sukolilo, Surabaya 60111, Indonesia

Email: [helvina.zahra@gmail.com](mailto:helvina.zahra@gmail.com), [arusdian@ie.its.ac.id](mailto:arusdian@ie.its.ac.id)\*

\*Corresponding author

---

**Abstract:** The growing demand for fresh products requires efficient and sustainable cold chain logistics, especially in last-mile delivery. Conventional refrigerated trucks utilized in last-mile logistics are hindered by high energy consumption, operational costs, and limited flexibility, creating a critical barrier for small-scale cold chain access. To address these inefficiencies, this research develops a Power-Free Smart Cooler Box that integrates Phase Change Material (PCM) technology with a high-performance composite structure to maintain frozen-grade temperatures without active power. The design methodology employed the Theory of Inventive Problem Solving (TRIZ) to systematically resolve the engineering contradiction between maximizing thermal endurance and minimizing system weight. The resulting configuration features a multi-layer insulation wall (Fiberglass/Vacuum Insulated Panel/Polyurethane) and a validated 6-sided PCM layout. This configuration enables the Smart Cooler Box to maintain an internal air temperature of  $\leq -10$  °C for more than 10 hours without external power. It is also equipped with a built-in IoT-based temperature sensor to ensure real-time traceability. These findings imply that the developed passive cooler provides a scientifically validated, zero-emission alternative that offers a flexible, energy-efficient, and environmentally friendly option for last-mile logistics while ensuring product safety in the final stage of delivery.

**Keywords:** Last-mile delivery, cold thermal energy storage, refrigerated container, TRIZ.

---

## Introduction

The increasing demand for fresh and perishable products drives the need for reliable storage and distribution systems capable of maintaining product quality [1]. This critical requirement is met through cold chain logistics, defined as a temperature-controlled supply chain that integrates the core components of handling, storage, transportation, and distribution to maintain product integrity from origin to destination [2]. Cold chain logistics play an important role in facilitating trade by ensuring the safe and efficient storage and distribution of temperature-sensitive goods. However, the intricate challenges posed by globalized supply chains and increasing climate variability significantly strain existing cold logistics systems. It is estimated that up to one-third (1/3) of total food produced globally is lost or wasted, a substantial portion of which is attributable to inadequate cold chain management and temperature deviations during distribution [3]. Consequently, the development of robust cold logistics solutions, capable of accurate and continuous temperature monitoring via technologies like IoT, is essential for reducing product spoilage and minimizing economic and environmental waste [4], [5].

These challenges are particularly acute in Indonesia, where the scope of cold chain logistics remains limited despite the country's status as a large archipelago with a high population density [6]. Indonesia's national logistics system still faces significant hurdles, as evidenced by its Logistics Performance Index (LPI) ranking, where infrastructure consistently receives one of the lowest scores [7]. This infrastructure inequality leads to a significant regional disparity, with services heavily centralized in Java and Sumatra, where energy availability and road networks are more established [8], [9]. In contrast, Eastern Indonesia faces a critical lack of cold chain services, where the development of logistics is stifled by limited electricity access in remote areas, insufficient

cold storage capacity, and exorbitantly high inter-island distribution costs [10], [11]. According to industry assessments by the Indonesian Cold Chain Association (ARPI), the industry's installed capacity falls significantly short, meeting only a fraction of the national demand required to support the country's vast marine and agricultural output. This inequality hinders the efficient distribution of fisheries and agricultural products from resource-rich remote islands to major consumption centers, often forcing producers to sell locally at lower prices or risk spoilage [12]. The inefficiency of this distribution process becomes a major contributor to post-harvest losses; recent government studies estimate that the horticulture sector is the most inefficient, with up to 62.8% of the domestic vegetable supply lost or wasted due to inadequate temperature management and handling [13].

Refrigerated trucks are the established solution for temperature-controlled transport, yet they are burdened by considerable drawbacks, including high energy consumption, high operational costs, and inherent limitations in distribution flexibility, especially for last-mile or smaller-volume deliveries [14]. Furthermore, the majority of Micro, Small, and Medium Enterprises (MSMEs) and small-scale fishermen in Indonesia cannot access expensive refrigeration solutions.

Alternatively, the use of refrigerated boxes is considered more energy-efficient and has a lower shipping cost compared to refrigerated trucks [15]. It is also considered more flexible, particularly when using modular designs that allow the boxes to be used on non-refrigerated vehicles. Unlike standard fixed-body trucks, these modular refrigerated boxes decouple the cold storage from the vehicle chassis, offering superior scalability and reducing the energy burden of cooling space. These systems generally employ two types of cooling: passive and active. Active cooling typically involves battery-powered vapor compression systems to ensure precise temperature control. Dewi *et al.* [16] successfully designed a refrigerated container for motorcycles using active compressor-based cooling systems. Another recent study has similarly explored compressor-based cooling systems to maintain thermal stability [17]. However, these active systems rely heavily on continuous electrical power, which increases operational complexity and carbon footprint, making them less economically and environmentally friendly.

Passive cooling avoids these penalties by utilizing coolant or cool storage panels to maintain a stable temperature without requiring an external power source [18]. Conventional passive options often rely on basic foam boxes with simple ice packs. However, as noted by Sha *et al.* [19], these traditional designs frequently fail to effectively utilize cold energy or meet strict storage requirements due to poor insulation and uneven cooling distribution. Phase Change Materials (PCMs) have emerged as a promising technology to enhance energy efficiency and significantly expand the operational flexibility of these containers within the cold chain [20]. PCM stores and releases thermal energy as latent heat during a phase transition, effectively acting as thermal shields that stabilize internal temperatures for extended periods without continuous external power [21], [22]. In practical applications, these PCMs are encapsulated into modular panels that line the interior of the refrigerated/cooler box. However, a significant research gap remains regarding the optimization of these panel layouts and their validation under dynamic last-mile delivery conditions [23].

During the distribution of low-temperature products, it is also critical to monitor the refrigerated container's internal temperature. It serves as the primary safeguard for product integrity and safety throughout the supply chain. The data derived from this monitoring is indispensable for decision-making, enabling the logistics operators to identify temperature fluctuations early and prevent potential undesirable events such as spoilage during delivery [24], [25]. IoT has emerged as a transformative technology for this purpose [26]. Consequently, the adoption of an IoT-based temperature monitoring system within refrigerated containers is becoming essential, as it provides real-time visibility to enhance cold chain logistics' efficiency and minimize waste [27].

This study distinguishes itself from existing cold chain solutions by addressing the critical gap between the high cost of active refrigeration and the inefficiency of traditional passive boxes. To address these needs and challenges, this study focuses on developing a passive cooler box design featuring an optimized PCM layout and container insulation material, thereby overcoming the deficiencies of traditional foam boxes, which lack thermal stability, high energy dependency, and the weight of compressor-based motorcycle containers. An IoT-based monitoring device is integrated into the cooler box design to ensure accurate, real-time temperature monitoring throughout the distribution process. This study aims to develop an innovative container design that is significantly more efficient and capable of maintaining controlled cooling temperatures down to  $-10^{\circ}\text{C}$  for extended durations of more than 10 hours. This development will contribute a crucial, validated solution to reduce food spoilage and enhance the sustainability of the cold supply chain.

## Methods

### TRIZ

The Theory of Inventive Problem Solving (TRIZ) is a systematic innovation methodology that provides structured tools for overcoming technical challenges and contradictions in engineering design. The method has been widely adopted in product development, sustainable engineering, and manufacturing because of its ability to transform conflicting requirements into opportunities for innovation [28].

In this study, TRIZ was used after gathering user requirements through interviews with a logistics company engaged in cold-chain delivery. The identified problem attributes and corresponding technical responses were translated into TRIZ engineering parameters and contradictions. The goal was to reach the Ideal Final Results (IFR), where the system delivers the desired function with minimal drawbacks [29]. For the Smart Cooler Box, the IFR is defined as a system that provides continuous, stable frozen-grade refrigeration ( $\leq -10^{\circ}\text{C}$ ) indefinitely while maintaining zero energy consumption, zero carbon emissions, and negligible structural weight. While a physical prototype cannot achieve this absolute ideal, the design uses this benchmark to prioritize passive Phase Change Materials (PCM) and high-efficiency vacuum insulation, moving the system as close as possible to "power-free" autonomy.

The application of TRIZ followed a structured sequence starting with the identification of specific design conflicts. Key contradictions encountered in this project included the need to enhance "Temperature stability (Parameter 17)" without increasing the "Weight of the moving object (Parameter 1)", and improving "Ease of operation (Parameter 33)" via sensor integration without increasing the "Complexity of the device (Parameter 36)". These contradictions were mapped onto Altshuller's 39 engineering parameters and cross-referenced with the contradiction matrix to identify relevant inventive principles, such as Phase Transitions, Composite Materials, and Equipotentiality.

The viability of the proposed Smart Cooler Box was assessed through a multi-stage evaluation approach, designed to transition the conceptual design toward a physical prototype:

**Design Constraints:** The prototype was required to adhere to strict regulatory and operational limits, specifically a maximum system weight of less than 30 kg and a minimum internal volume of approximately 220 L. Furthermore, external dimensions were strictly constrained by Indonesian government regulation Permenhub PM No. 60/2019 to ensure load stability and safety during motorcycle-based last-mile transport.

**Prototyping Feasibility:** Feasibility was assessed by evaluating the manufacturability of the design using locally available materials. The selection of the materials was based on their accessibility and the ability to process them into a high-performance composite structure within current manufacturing constraints.

**Methodological Modeling:** Performance was validated through iterative CAD modeling in Autodesk Fusion, supported by concept-level material and layout simulations to predict cooling duration and thermal leakage at modular interfaces. This modeling phase was essential for optimizing the PCM cartridge arrangement and identifying potential thermal bridges before physical construction.

**Performance Indicators:** The design was measured against definitive technical benchmarks: achieving a minimum internal air temperature of  $\leq -10^{\circ}\text{C}$ , maintaining this temperature for more than 10 hours without external power, and ensuring tool-free maintenance for rapid PCM replacement and sanitization.

Applying TRIZ in this study provides a structured framework for designing the Smart Cooler Box without compromising between conflicting objectives. This framework proved essential in explicitly resolving key technical contradictions, most notably the trade-offs between extending cooling duration versus minimizing PCM weight, ensuring modular adaptability without risking thermal leakage, and integrating IoT sensors without increasing operational complexity. By systematically analyzing contradictions and translating them into inventive principles, TRIZ guides the generation of solutions that balance performance, usability, and manufacturability. This approach ensures the final design is aligned with concrete user needs, specifically enabling energy-independent cold chain access for MSMEs, reducing carbon footprint, and reducing post-harvest losses in regions with limited infrastructure. In this way, TRIZ functions as both a problem-solving and

innovation tool, supporting the transition from abstract requirements into concrete design strategies that strengthen the overall development process of the Smart Cooler Box.

## Results and Discussions

### TRIZ-Based Technical Analysis

In developing the Power-Free Smart Cooler Box design to support the delivery of temperature-sensitive products, a semi-structured, in-depth interview was conducted with a logistics company that is currently expanding into the cold chain logistics sector. The interview involved key operational stakeholders, specifically the operations manager and logistics planner. The purpose of this interview was to gather information on the actual operational conditions of cold product delivery at the company, identify the problems encountered, and understand users' expectations and technical requirements (user requirements) for the development of the ideal Smart Cooler Box.

The results of this interview are an important basis for the design process because they provide direct insight from potential users, including technical constraints, operational limitations, and expected features. The qualitative data gathered from the interview were subjected to thematic categorization. This process distilled the raw feedback into two distinct elements [30]:

**Problem Attributes:** A categorization of the recurring challenges, needs, and limitations faced by the users.

**Technical Responses:** The potential technical solutions identified to address these specific attributes.

This structure aims to identify potential technical contradictions and design-innovation opportunities that can be developed through a systematic TRIZ-based approach. The mapping results are shown in Table 1.

**Table 1.** Problem attributes and technical responses

No.	Problem Attributes	Technical Responses	Priority
1	High investment cost for active refrigeration	Utilize standard modular components and economical composite materials to minimize cost.	High
2	Requirement for real-time tracking	Integrated IoT module with real-time temperature monitoring and Bluetooth/Wi-Fi connectivity	High
3	Short cooling duration ( $\pm 4$ hours)	Passive PCM system capable of maintaining temperature without external power	High
4	Limited delivery range	Thermal autonomy enabling inter-city transport capability	High
5	Demand for multi-product handling	Adjustable internal layout with modular PCM slots and removable shelves/compartments	Medium
6	Compatibility with motorcycles & vans	Flexible modular container design, dual-mode dimensions compliant with Permenhub PM 60/2019	High
7	Heavy or fragile construction	Multi-layer composite structure	Medium
8	Difficulty in maintenance	Detachable PCM cartridges and an accessible inner liner for easy cleaning and replacement	Medium
9	Large capacity requirements	Thin-wall insulation design optimized to achieve high internal volume	High
10	Product safety	PCM cartridge arrangement to ensure uniform temperature distribution	High

The analysis presented in Table 1 highlights that the most critical design imperatives center on economic accessibility, thermal autonomy, and regulatory compliance. The technical responses address the user's financial constraints by adopting passive PCM cooling and modular construction, effectively eliminating the high operational costs associated with active refrigeration. The requirement for extended delivery ranges is met by the proposed multi-layer composite structure, which aims to maximize thermal inertia while adhering to the strict weight and dimension limits for motorcycle transport mandated by Permenhub PM 60/2019. However, implementing these technical responses simultaneously introduces inherent engineering conflicts, necessitating the subsequent application of the TRIZ methodology to resolve these contradictions.

As indicated in Table 1, attempting to satisfy one requirement often negatively affects another. For instance, the user demand for extended cooling duration necessitates robust insulation, which typically increases the container's weight—a direct violation of the lightweight requirement for motorcycle transport. To systematically resolve these contradictions, the TRIZ Contradiction Matrix approach was used. This process involved

translating the specific operational hurdles into Altshuller’s 39 standardized engineering parameters. By mapping the "Improving Feature" against the "Worsening Feature," the analysis isolated the core technical contradictions governing the design:

Temperature vs. Weight: The primary objective to strictly maintain  $-10^{\circ}\text{C}$  (Parameter 17: Temperature) traditionally requires heavy insulation or large ice masses, which contradicts the need to minimize the Weight of the moving object (Parameter 1).

Insulation vs. Capacity: To prevent thermal leakage (Parameter 22: Loss of Energy), insulation thickness is usually increased. However, in a fixed-dimension container, this reduces the usable internal cargo space (Parameter 7: Volume of moving object).

Modularity vs. Complexity: The requirement for a flexible, multi-compartment layout (Parameter 35: Adaptability) introduces additional joints and parts, thereby increasing the system’s assembly difficulty (Parameter 36: Complexity of device).

These parameter pairs were cross-referenced in the Contradiction Matrix to identify relevant Inventive Principles (such as Phase Transitions and Composite Materials). These principles served as conceptual bridges, converting abstract contradictions into concrete engineering solutions. Table 2 details this analytical process, presenting the identified contradictions, the selected inventive principles, and the specific design features derived to resolve them.

**Table 2.** Contradiction matrix, inventive principles, solutions

No.	Contradiction		Inventive Principles	Design Outcome
	Improving Feature	Worsening Feature		
1	17. Temperature	1. Weight of moving object	36. Phase transitions; 22. Blessing in disguise: Replacing active cooling with PCM reframes mass as functional latent heat storage rather than dead weight [20].	Modular PCM cartridges provide long cooling duration without excessive system weight.
2	17. Temperature	7. Volume of moving object	40. Composite materials: enable combining VIP with PU foam and fiberglass, achieving high thermal resistance while minimizing wall thickness [31], [32].	Thin composite insulation walls preserve internal payload volume.
3	35. Adaptability or versatility	30. Object-affected harmful	31. Porous materials; 11. Beforehand cushioning: Using porous PU foam to fill structural cavities mitigates thermal bridging at modular joints [33].	Composite Gap Filling: Utilizing PU Foam (Porous Material) to fill cavities between the VIP and outer fiberglass shell ensures that modular joints are sealed against heat leakage.
4	33. Ease of operation	36. Complexity of device	12. Equipotentiality; 17. Another dimension: Integrated IoT sensors enable tracking without interfering with internal thermal gradients [5].	Built-in IoT sensors integrated into detachable side/interface modules.
5	22. Loss of energy	2. Weight of stationary object	28. Mechanics substitution; 15. Dynamics: Substituting thick foam with high-efficiency VIP allows for dynamic optimization of insulation mass [31], [32].	Energy-efficient insulation achieved without excessive structural weight.
6	4. Length of moving object	7. Volume of moving object	7. Nested doll; 17. Another dimension: Embedding PCM within wall cavities (recessed slots) preserves internal volume while meeting vehicle size limits [34].	Compact external dimensions with optimized internal volume.
7	25. Loss of time	27. Reliability	1. Segmentation; 10. Preliminary action: Pre-conditioning PCM before dispatch to ensure stable performance over long routes [35].	Reliable temperature maintenance during extended last-mile delivery.
8	35. Adaptability or versatility	21. Power (supply)	1. Segmentation; 29. Pneumatics and hydraulics: Modular PCM cartridges enable adjustment of cooling capacity based on the specific delivery payload [36].	Fully power-free operation with adaptable cooling capacity.

The abstract design outcomes (Table 2) were translated into concrete, measurable target specifications. For instance, the TRIZ solution of using "Phase Transitions" (Principle 36) to replace active cooling led to the specific

requirement for a passive system capable of maintaining an internal air temperature of  $\leq -10^{\circ}\text{C}$ . This target was selected to align with the standard frozen shipping category (typically  $-10^{\circ}\text{C}$  to  $-20^{\circ}\text{C}$ ) used for transporting frozen meat, poultry, and pre-packaged frozen foods [37]. Maintaining this threshold is critical for last-mile logistics to prevent micro-thawing events that compromise texture and safety during the final stage of delivery.

Similarly, the "Mechanics Substitution" (Principle 28) outcome—replacing bulk foam with high-efficiency composites—defined the strict 50 mm wall thickness limit to maximize internal volume. These specifications serve as the definitive technical benchmarks for the prototyping phase, ensuring the final product meets the operational needs of last-mile logistics while adhering to the regulatory constraints of Permenhub PM 60/2019. The comprehensive list of these target specifications, along with their corresponding TRIZ design outcomes, is presented in Table 3.

**Table 3.** Target specifications of smart cooler box

Aspect	Target Specification	Related TRIZ Design Outcome (Table 2)
Cost	Passive cooling system with no active refrigeration components	Power-free cooling (Rows 1, 8)
Efficiency	(requiring no fuel/electricity for refrigeration during delivery)	
Cooling System	Modular PCM cartridge system; cooling duration $\geq 10$ hours without external power	Phase transition & segmentation (Rows 1, 8)
Cooling Performance	Minimum achievable internal air temperature: $\leq -10^{\circ}\text{C}$ under design load conditions	Temperature vs. weight resolution (Row 1)
Internal Modularity	Adjustable internal layout with removable shelves and PCM slots; reconfiguration time $\leq 10$ minutes	Adaptability vs. energy loss (Row 3)
Transport Flexibility	Compatible with motorcycle and light van transport; dimensions compliant with Permenhub PM No. 60/2019	Compactness & adaptability (Rows 6, 8)
Insulation Structure	PU-Foam + VIP + Fiberglass composite	Composite materials principle (Row 2)
Maintenance	Tool-free replacement of PCM cartridges and detachable inner liners for rapid sanitization	Energy loss vs. weight (Row 5) Ease of maintenance vs. complexity (Row 4)
Physical Dimensions	External dimensions of the container: - Main compartment $900\text{ (D)} \times 600\text{ (W)} \times 600\text{ (H)}$ mm - Leg compartment $200\text{ (D)} \times 600\text{ (W)} \times 500\text{ (H)}$ mm Insulation wall thickness 50 mm, resulting in internal dimensions of the container: - Main compartment $800\text{ (W)} \times 500\text{ (L)} \times 500\text{ (H)}$ mm - Leg compartment $100\text{ (W)} \times 500\text{ (L)} \times 400\text{ (H)}$ mm Distance between leg compartments 500 mm	Volume preservation (Rows 2, 6)
Volume	Approx. 220 liters	Volume preservation (Rows 2, 6)
Temperature Sensor	Real-time Sensor: Range $-55^{\circ}\text{C}$ to $125^{\circ}\text{C}$ ; Accuracy $\pm 0.5^{\circ}\text{C}$ ; Battery Life $>12$ hours; Connectivity: Bluetooth/WiFi	Ease of operation vs. complexity (Row 4)

### Cooling System with Phase Change Materials (PCMs)

The cooling system used is a Cold Thermal Energy Storage (CTES) system that utilizes Phase Change Material (PCM). PCM can be stored in modular cartridges, and the quantity can be adjusted as needed. The use of PCM aims to maintain a cold temperature inside the Smart Cooler Box during shipping.

PCM cartridges are used to maintain temperature stability in the cold chain. These cartridges are modular, leak-proof, and stackable so that they can be used according to the capacity needed in cooler boxes or containers. In terms of thermal capability, the cartridges provide temperature regulation, ensuring that temperature-sensitive products (such as food and pharmaceuticals) remain within a safe range during transportation and storage [15], [38]. The duration of cooling depends on the number of panels used and the insulation capacity of the box [20], [32].

Studies by Gan *et al.* [36], Du *et al.* [31], and Yenare *et al.* [39] consistently demonstrate that the most effective PCM arrangement in portable cold storage systems is when the PCM is placed on all six walls of the box: the top, bottom, and four sides of the container. This layout achieved the longest cooling duration (27–46.5 hours), the highest discharging efficiency (over 90%), and the most uniform internal temperature distribution. By fully enclosing the chamber, the PCM absorbed heat uniformly from every direction, reducing temperature fluctuations and hot spots. The studies also emphasized that this configuration enhances natural convection

and balances heat transfer, leading to longer, steadier, and more efficient cooling performance compared to side-only or top/bottom-only layouts.

Based on these findings, the Smart Cooler Box will adopt a design where PCM cartridges are installed on all six inner walls (Figure 1). This configuration ensures maximum thermal coverage, superior temperature uniformity, and extended passive cooling duration, enabling the Smart Cooler Box to maintain a stable environment at  $\leq -10^{\circ}\text{C}$  for sensitive goods without external power.

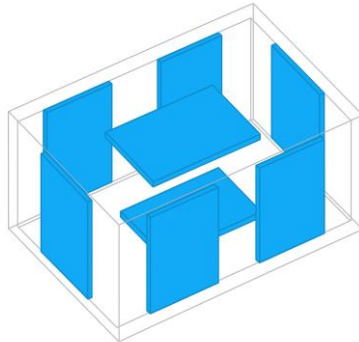

**Figure 1.** Proposed PCM cartridge layout [36]

### Insulation Structure Selection

The selected structural material is a multi-layer composite that combines fiberglass for the outer wall, with Polyurethane (PU) Foam and Vacuum Insulated Panels (VIP) utilized for insulation within the wall cavity [40]. This combination is chosen to leverage the strengths of each material:

Fiberglass (outer wall): Provides a durable and relatively light outer shell for physical protection and wear resistance [41].

Vacuum Insulated Panel (VIP): Offers extremely low thermal conductivity (as low as  $<0,002$  W/mK and high R-value per unit of thickness [33]). VIP is critical for achieving high insulation performance in a space-constrained design and for supporting long cold-holding times. Du *et. al* [31] demonstrated that when VIPs are optimally integrated into PCM-based coolers, they can support extended cold-holding times—reaching up to 46.5 hours in numerically simulated scenarios validated by experimental models.

Polyurethane (PU) Foam: Has a typical thermal conductivity of  $0,020 - 0,025$  W/mK. It serves as a protective and support layer for the fragile VIP, helping to minimize thermal bridges and offering a relatively light material that is easy to shape [33].

The combined multi-layer structure aims for a very low effective thermal conductivity for the overall composite. By embedding VIPs within the PU foam matrix, the design targets an effective system conductivity of approximately  $0.006-0.008$  W/mK. This value is significantly lower than pure foam insulation, ensuring the system meets the  $-10^{\circ}\text{C}$  target for over 10 hours without external power.

### Design of the Power-Free Smart Cooler Box

The final design of the Smart Cooler Box (Figure 2) represents a synthesis of the technical solutions derived from the TRIZ analysis, directly addressing the core contradictions identified in Table 2. The design architecture functions as a cohesive system where each component plays a specific role in meeting the target specifications.

The primary trade-off between cooling performance and system weight is addressed by combining a passive PCM-based cooling system with a composite wall structure. Modular PCM cartridges utilize phase-transition latent heat to maintain low temperatures without active refrigeration, eliminating heavy compressors and power supplies. Simultaneously, the composite wall of fiberglass, VIP, and PU foam achieves high thermal resistance with limited thickness, resolving the conflict between insulation effectiveness and internal volume. This combination enables the Smart Cooler Box to maintain a target minimum internal air temperature of  $-10^{\circ}\text{C}$  for more than 10 hours while keeping the total empty weight below 30 kg.

The six-sided PCM cartridge layout further enhances thermal stability and directly addresses user concerns related to product safety and uneven temperature distribution. To implement this full coverage without consuming valuable cargo space, the design employs a 'Nested Doll' configuration, utilizing recessed slots molded into the liner to mount the cartridges flush against the wall. This integration maximizes usable internal volume while firmly securing the cooling mass, effectively resolving the trade-off among extended delivery duration, payload capacity, and reliability in last-mile delivery.

A critical component that enables the cooler box's "smart" capabilities is the integrated IoT Temperature Sensor. This feature directly addresses the user requirement for product safety and real-time tracking by balancing ease of operation and complexity. Instead of relying on manual logs, the built-in sensor automatically monitors conditions from  $-55\text{ }^{\circ}\text{C}$  to  $125\text{ }^{\circ}\text{C}$ . The system is programmed with a critical safety threshold: if the internal temperature rises above  $10\text{ }^{\circ}\text{C}$  (the upper limit for safe cold delivery), it immediately triggers an alert via the connected smartphone app. This proactive notification system transforms the cooler box from a simple storage container into an active quality-assurance tool, ensuring traceability and reducing spoilage risk throughout last-mile delivery.

The dimensional specifications were defined to ensure regulatory compliance and operational efficiency. The external dimensions of  $900\text{ (L)} \times 600\text{ (W)} \times 600\text{ (H)}$  mm adhere strictly to the Permenhub PM 60/2019 standards for motorcycle cargo, keeping the load within safe handlebar-width and seat-height limits. The internal dimensions were calculated not only to achieve the  $\sim 220$ -liter capacity target but also to accommodate the partner logistics company's standardized packaging sizes. This precise internal sizing eliminates wasted "dead space" and addresses the large-capacity attributes identified in the user requirements. The detailed parts of the Smart Cooler Box are shown in Table 4.

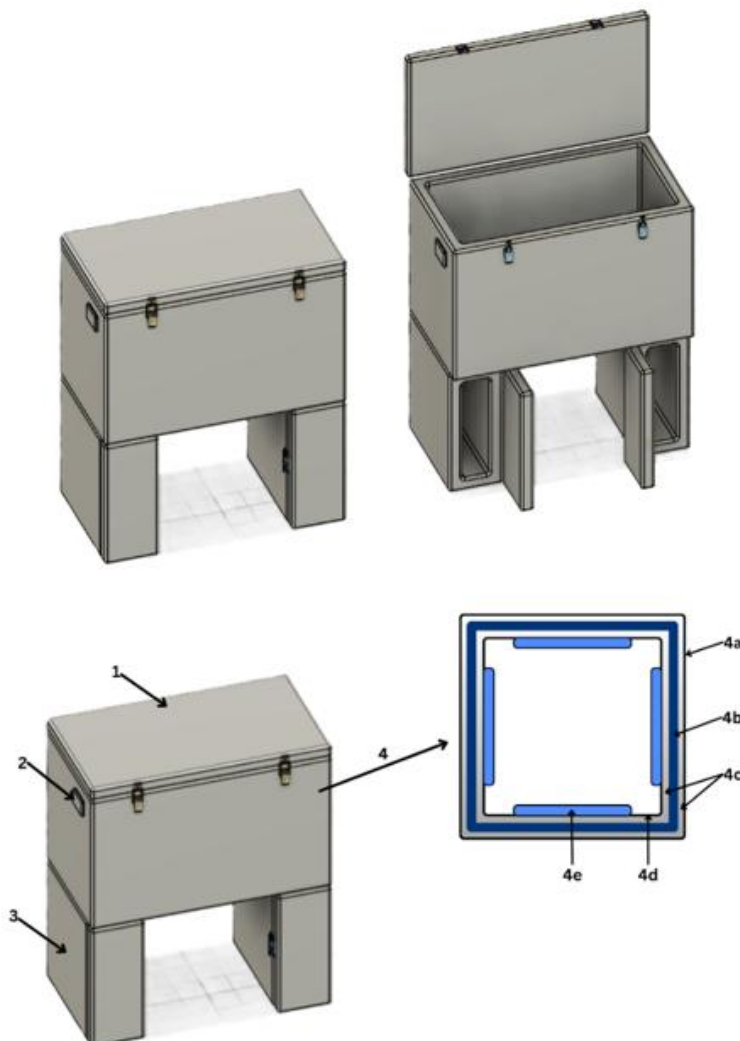

**Figure 2.** Final design of the power-free smart cooler box

**Table 4.** Detailed parts of smart cooler box

No.	Part Name
1	Main compartment
2	Temperature Sensor with IoT
3	Leg compartment
4	Container wall
4a	Outer wall – fiberglass
4b	Vacuum Insulation Panel (VIP)
4c	PU-Foam
4d	Inner wall
4e	PCM cartridge

## Conclusions

The design and development of the Power-Free Smart Cooler Box addressed the critical need for an efficient, flexible, power-independent solution for last-mile cold chain logistics. This study presents a TRIZ-based design framework for developing a Power-Free Smart Cooler Box tailored to last-mile cold-chain logistics, with a specific focus on energy independence, modularity, and operational reliability. The primary contribution of this research lies in the systematic application of TRIZ to translate user-derived problems into engineering contradictions and resolve them through a coherent integration of passive PCM-based cooling, composite insulation structures, modular architecture, and smart monitoring. Rather than optimizing individual components in isolation, the proposed framework demonstrates how conflicting requirements can be resolved simultaneously within a single product architecture.

The final design introduces a novel passive cooling configuration that combines modular PCM cartridges with a six-sided PCM layout and a high-performance composite wall structure. This configuration enables the Smart Cooler Box to maintain an internal air temperature of  $\leq -10$  °C for more than 10 hours without external power, while meeting motorcycle cargo regulations and providing an internal volume of approximately 220 liters. The modular PCM system allows cooling capacity to be adjusted according to delivery duration and payload, directly addressing the adaptability and transport flexibility requirements identified in the user requirements.

The Smart Cooler Box is distinguished by its built-in IoT-based sensor system, which addresses the need for real-time tracking and product safety. By providing real-time visibility and instant alerts for threshold deviations ( $>10$ °C), the IoT architecture transforms the passive container into an active quality-assurance tool, enhancing traceability and reducing spoilage risk without the energy burden of active refrigeration.

Despite these contributions, this study is subject to several limitations. The current work is primarily based on conceptual design and simulation-informed specifications, and the thermal performance targets rely on assumptions regarding PCM conditioning, ambient conditions, and ideal insulation integration. Additionally, the economic feasibility of large-scale production, particularly the cost implications of VIP materials, has not yet been experimentally validated. The system's performance also depends on proper PCM pre-conditioning before dispatch, which introduces an operational dependency that must be addressed in real-world deployment.

Future research will therefore focus on experimental validation of the developed prototype, including measurements of cooling duration, temperature uniformity, and thermal degradation under varying ambient and loading conditions. Further work will also include manufacturability and assembly testing, ergonomic evaluation for motorcycle handling, and cost-benefit and lifecycle assessments to quantify environmental and economic impacts. These extensions are essential to transition the Smart Cooler Box from a validated conceptual design to a deployable solution capable of supporting MSMEs and improving cold chain accessibility in regions with limited infrastructure.

## Acknowledgment

This research is funded by Kementerian Pendidikan Tinggi, Sains, dan Teknologi (Kemdiktisaintek), grant Basis Informasi Penelitian dan Pengabdian kepada Masyarakat (BIMA) – Penelitian Tesis Magister.

## References

- [1] J. Han, C. Sun, Z. Ji, and X. Yang, "Smart cold chain logistics for fresh agricultural products: Key technologies, challenges, and future trends," *Trends Food Sci. Technol.*, vol. 167, p. 105421, Jan. 2026, doi: <https://doi.org/10.1016/j.tifs.2025.105421>.

- [2] J.-W. Han, M. Zuo, W.-Y. Zhu, J.-H. Zuo, E.-L. Lü, and X.-T. Yang, "A comprehensive review of cold chain logistics for fresh agricultural products: Current status, challenges, and future trends," *Trends Food Sci. Technol.*, vol. 109, pp. 536–551, Mar. 2021, doi: <https://doi.org/10.1016/j.tifs.2021.01.066>.
- [3] UN Environment Programme, "Sustainable cold chain and food loss reduction," Nov. 2019. Accessed: Apr. 04, 2025. [Online]. Available: [https://ozone.unep.org/system/files/documents/MOP31-Sustainable-HL\\_Briefing\\_Note.pdf](https://ozone.unep.org/system/files/documents/MOP31-Sustainable-HL_Briefing_Note.pdf)
- [4] H. Zhao, S. Liu, C. Tian, G. Yan, and D. Wang, "An overview of current status of cold chain in China," *International Journal of Refrigeration*, vol. 88, pp. 483–495, Apr. 2018, doi: <https://doi.org/10.1016/j.ijrefrig.2018.02.024>.
- [5] X. Wang *et al.*, "Pathways toward precise monitoring and low-carbon sustainability in fruit cold chain logistics: A solution enabled by flexible temperature sensing," *Materials Today Sustainability*, vol. 24, Dec. 2023, doi: <https://doi.org/10.1016/j.mtsust.2023.100592>.
- [6] MarkNtel Advisors, "Indonesia cold chain market research report: Forecast (2025-2030)," 2025. Accessed: Jan. 02, 2026. [Online]. Available: <https://www.marknteladvisors.com/research-library/indonesia-cold-chain-market.html>
- [7] P. D. Sentia, R. Ramadani, and S. Zuhri, "Logistic performance measurement on a port in Aceh," *Jurnal Teknik Industri: Jurnal Keilmuan dan Aplikasi Teknik Industri*, vol. 20, no. 1, pp. 59–64, Jun. 2018, doi: <https://doi.org/10.9744/jti.20.1.59-64>.
- [8] International Trade Administration, "Indonesia cold chain industry," *Market Intelligence*. Accessed: Sep. 25, 2025. [Online]. Available: <https://www.trade.gov/market-intelligence/indonesia-cold-chain-industry>
- [9] Y. Sahu, "Indonesia cold chain logistics market outlook to 2030," Dec. 2024. Accessed: Jan. 02, 2026. [Online]. Available: <https://www.kenresearch.com/industry-reports/indonesia-cold-chain-logistics-market>
- [10] P. B. Utomo, Mustaruddin, Mulyono, and R. Muningsgar, "Measuring the fish logistics performance index in the Indonesian fisheries supply chains (A study case of poumako fishing port of Mimika, Central Papua)," in *BIO Web of Conferences*, EDP Sciences, Feb. 2024. doi: <https://doi.org/10.1051/bioconf/20249201029>.
- [11] PT Capricorn Indonesia Consult, "A cold chain study of Indonesia," Jakarta, 2019. Accessed: Dec. 30, 2025. [Online]. Available: [https://www.eria.org/uploads/media/8\\_RPR\\_FY2018\\_11\\_Chapter\\_4.pdf](https://www.eria.org/uploads/media/8_RPR_FY2018_11_Chapter_4.pdf)
- [12] H. Kurniawati and X. Zhang, "Intra-regional disparity in Kalimantan: Implications of capital city relocation," Singapore, Aug. 2023. Accessed: Sep. 25, 2025. [Online]. Available: <https://lkyspp.nus.edu.sg/docs/default-source/aci/acirp202314.pdf>
- [13] Ministry of National Development Planning/Bappenas, "Food loss and waste in Indonesia," 2021. Accessed: Sep. 25, 2025. [Online]. Available: <https://lcdi-indonesia.id/wp-content/uploads/2021/07/Executive-Summary-FLW-ENG.pdf>
- [14] S. Tong *et al.*, "A phase change material (PCM) based passively cooled container for integrated road-rail cold chain transportation – An experimental study," *Appl. Therm. Eng.*, vol. 195, Aug. 2021, doi: <https://doi.org/10.1016/j.applthermaleng.2021.117204>.
- [15] R. R. Yenare *et al.*, "A comprehensive review of portable cold storage: Technologies, applications, and future trends," *Alexandria Engineering Journal*, vol. 94, pp.23-33, May 2024, doi: <https://doi.org/10.1016/j.aej.2024.03.014>.
- [16] R. S. Dewi, A. Rusdiansyah, and F. Herdiansyah, "Perancangan kontainer berpendingin pada sepeda motor dengan metoda QFD dan TRIZ," *INVOTEK: Jurnal Inovasi Vokasional dan Teknologi*, vol. 20, no. 1, pp. 13–26, Feb. 2020, doi: <https://doi.org/10.24036/invotek.v20i1.752>.
- [17] I. Santosa, I. Wainawa, A. Saptika, and I. Budiarta, "Design analysis of transportation refrigeration container with photovoltaic and compatible to electric vehicle," in *Proceedings of the 5th International Conference on Applied Science and Technology on Engineering Science*, SCITEPRESS - Science and Technology Publications, 2022, pp. 541–546. doi: <https://doi.org/10.5220/0011819800003575>.
- [18] T. B. Umate and P. D. Sawarkar, "A review on thermal energy storage using phase change materials for refrigerated trucks: Active and passive approaches," *J. Energy Storage*, vol. 75, p. 109704, Jan. 2024, doi: <https://doi.org/10.1016/j.est.2023.109704>.
- [19] Y. Sha, W. Hua, H. Cao, and X. Zhang, "Properties and encapsulation forms of phase change material and various types of cold storage box for cold chain logistics: A review," *J. Energy Storage*, vol. 55, p. 105426, Nov. 2022, doi: <https://doi.org/10.1016/j.est.2022.105426>.
- [20] S. Burgess, X. Wang, A. Rahbari, and M. Hangi, "Optimisation of a portable phase-change material (PCM) storage system for emerging cold-chain delivery applications," *J. Energy Storage*, vol. 52, Aug. 2022, doi: <https://doi.org/10.1016/j.est.2022.104855>.
- [21] N. Kapilan, K. A. Kumar, and K. Gowda, "Recent advances in applications of phase change materials in cold storage - A review," in *Materials Today: Proceedings*, Elsevier Ltd, 2021, pp. 2410–2414. doi: <https://doi.org/10.1016/j.matpr.2021.04.442>.

- [22] X. Xu, X. Zhang, and J. M. Munyalo, “Key technologies and research progress on enhanced characteristics of cold thermal energy storage,” *Journal of Molecular Liquids*, vol. 278, pp. 428-237, Mar. 15, 2019, doi: <https://doi.org/10.1016/j.molliq.2019.01.040>.
- [23] B. Huang, S. Yang, J. Wang, and P. D. Lund, “Optimizing the shape of PCM container to enhance the melting process,” *Oxford Open Energy*, vol. 1, Jan. 2022, doi: <https://doi.org/10.1093/ooenergy/oiab006>.
- [24] R. Badia-Melis, U. Mc Carthy, L. Ruiz-Garcia, J. Garcia-Hierro, and J. I. Robla Villalba, “New trends in cold chain monitoring applications - A review,” *Food Control*, vol. 86, pp. 170-182, Apr. 01, 2018, doi: <https://doi.org/10.1016/j.foodcont.2017.11.022>.
- [25] A. Chaudhuri, I. Dukovska-Popovska, N. Subramanian, H. K. Chan, and R. Bai, “Decision-making in cold chain logistics using data analytics: A literature review,” *The International Journal of Logistics Management*, vol. 29, no. 3, pp. 839–861, Aug. 2018, doi: <https://doi.org/10.1108/IJLM-03-2017-0059>.
- [26] S. S. Kamble, A. Gunasekaran, H. Parekh, and S. Joshi, “Modeling the internet of things adoption barriers in food retail supply chains,” *Journal of Retailing and Consumer Services*, vol. 48, pp. 154–168, May 2019, doi: <https://doi.org/10.1016/j.jretconser.2019.02.020>.
- [27] A. Y. Cil, D. Abdurahman, and I. Cil, “Internet of Things enabled real time cold chain monitoring in a container port,” *Journal of Shipping and Trade*, vol. 7, no. 1, Dec. 2022, doi: <https://doi.org/10.1186/s41072-022-00110-z>.
- [28] S. Kandukuri, E. E. Günay, O. Al-Araidah, and G. E. Okudan Kremer, “Inventive solutions for remanufacturing using additive manufacturing: ETRIZ,” *J. Clean. Prod.*, vol. 305, Jul. 2021, doi: <https://doi.org/10.1016/j.jclepro.2021.126992>.
- [29] D. Russo and C. Spreafico, “TRIZ-Based Guidelines for Eco-Improvement,” *Sustainability*, vol. 12, no. 8, 2020, doi: <https://doi.org/10.3390/su12083412>
- [30] V. Petrov, *TRIZ. Theory of Inventive Problem Solving: Level 1*. Springer International Publishing, 2019. doi: <https://doi.org/10.1007/978-3-030-04254-7>.
- [31] J. Du, B. Nie, Y. Zhang, Z. Du, li Wang, and Y. Ding, “Cooling performance of a thermal energy storage-based portable box for cold chain applications,” *J. Energy Storage*, vol. 28, Apr. 2020, doi: <https://doi.org/10.1016/j.est.2020.101238>.
- [32] X. Xiaofeng and Z. Xuelai, “Simulation and experimental investigation of a multi-temperature insulation box with phase change materials for cold storage,” *J. Food Eng.*, vol. 292, Mar. 2021, doi: <https://doi.org/10.1016/j.jfoodeng.2020.110286>.
- [33] S. Verma and H. Singh, “Vacuum insulation in cold chain equipment: A review,” *Energy Procedia*, vol. 161, pp. 232–241, Mar. 2019, doi: <https://doi.org/10.1016/j.egypro.2019.02.086>.
- [34] A. K. Ray, S. Singh, D. Rakshit, and Udayraj, “Comparative study of cooling performance for portable cold storage box using phase change medium,” *Thermal Science and Engineering Progress*, vol. 27, Jan. 2022, doi: <https://doi.org/10.1016/j.tsep.2021.101146>.
- [35] N. Ndraha, H. I. Hsiao, J. Vlajic, M. F. Yang, and H. T. V. Lin, “Time-temperature abuse in the food cold chain: Review of issues, challenges, and recommendations,” Jul. 01, 2018, *Elsevier Ltd.* doi: <https://doi.org/10.1016/j.foodcont.2018.01.027>.
- [36] Q. Gan, Y. Zhang, Z. Zhang, M. Chen, J. Zhao, and X. Wang, “Influencing factors of cooling performance of portable cold storage box for vaccine supply chain: An experimental study,” *J. Energy Storage*, vol. 72, Nov. 2023, doi: <https://doi.org/10.1016/j.est.2023.108212>.
- [37] J.-P. Rodrigue, *The Geography of Transport Systems*. London: Routledge, 2024. doi: <https://doi.org/10.4324/9781003343196>.
- [38] M. Calati, K. Hooman, and S. Mancin, “Thermal storage based on phase change materials (PCMs) for refrigerated transport and distribution applications along the cold chain: A review,” *International Journal of Thermofluids*, vol. 16, Nov. 2022, doi: <https://doi.org/10.1016/j.ijft.2022.100224>.
- [39] R. R. Yenare *et al.*, “Numerical analysis of phase change material placement and temperature effects in cold storage systems,” *Alexandria Engineering Journal*, vol. 129, pp. 1024–1038, Oct. 2025, doi: <https://doi.org/10.1016/j.aej.2025.07.019>.
- [40] L. Huang and U. Piontek, “Improving performance of cold-chain insulated container with phase change material: An experimental investigation,” *Applied Sciences (Switzerland)*, vol. 7, no. 12, Dec. 2017, doi: <https://doi.org/10.3390/app7121288>.
- [41] M. Khairulmaini, Z. Michael, M. A. M. Shah, M. S. Zakaria, B. Abdullah, and A. A. Rashid, “Improvement of insulation material for cool box application,” *IOP Conf. Ser. Mater. Sci. Eng.*, vol. 834, no. 1, p. 012019, Apr. 2020, doi: <https://doi.org/10.1088/1757-899X/834/1/012019>.